

# QUANTUM® R-TRAK

## PRODUCT SPECIFICATIONS SHEET

Class of Use	B (Group 3)
Weight Capacity	300 lbs. (136 kg/21 stone 6 lbs.)
Maximum Speed <sup>1</sup>	Up to 7 mph (11 km/h) Up to 3.5 mph (5.6 km/h) with 10-in. lift
Ground Clearance <sup>2</sup>	3.97 in. (101 mm) at battery tray
Turning Radius <sup>2</sup>	25.7 in. (653 mm)
Overall Size <sup>2,6</sup>	Stowage Length: 34.8 in (884 mm) without front riggings Length: 44.5 in. (1130 mm) with front riggings Width: 24.2 in. (616 mm)
Drive Wheels	14 in. (356 mm), solid or pneumatic
Caster Wheels	9 in. (229 mm), solid
Anti-tip Wheels	4 in. (102 mm), flat free
Range <sup>1,4</sup>	Up to 16.34 miles (26.3 km) with Group 24 batteries
Component Weights <sup>5</sup>	Base: 128 lbs. (58 kg) Batteries: Group 24: 51.5 lbs. (23.36 kg) each (standard)
Drivetrain	Two motor, rear-wheel drive
Brakes	Electronic regenerative, disc park brake
Batteries <sup>3</sup>	Two 12 volt, Flat top deep-cycle Group 24: C20 75 Ah, C5 62 Ah
Battery Charger	8 amp, off-board
Freewheel Operational Force	Less than 60 N
Drive Control Operational Force	Less than 5 N
Maximum Rated Slope	7.5° (13.2%)
Maximum Obstacle Climbing Ability (Ascending and Descending)	2.36 in. (60 mm)
Measured Sound Level (A-weighted)	Less than 65 dB

<sup>1</sup> Varies with base model, user weight, terrain type, battery amp hour rating (Ah), battery charge, battery condition, motors, controller type, tire type, and tire condition. This specification is subject to a variance of +10%, -5%.

<sup>2</sup> Due to manufacturing tolerances and continued product improvement, this specification can be subject to a variance of (+ or -) 3%.

<sup>3</sup> AGM, Gel-Cell, or Hybrid Gel (Hybrid Gel is defined as Nano Silica Gel Electrolyte with High Quality Glass Mat Separators) type required. See "Batteries and Charging."

<sup>4</sup> Tested in accordance with ANSI/RESNA, WC Vol. 2, Section 4 & ISO 7176-4 standards. Results derived from theoretical calculations based on battery specifications and drive system performance. Test conducted at maximum weight capacity.

<sup>5</sup> Battery weight may vary based on manufacturer.

<sup>6</sup> Dimensions listed are for power base only. Overall measurements will vary based on seating and accessory selections.

**NOTE: This product conforms to all applicable ANSI/RESNA, ISO 7176 Series, AS/NZS 3695.2, and EN12184 standards. All specifications subject to change without notice.**

Rev B/August 2023



# QUANTUM<sup>®</sup> R-TRAK

## PRODUCT SPECIFICATIONS SHEET

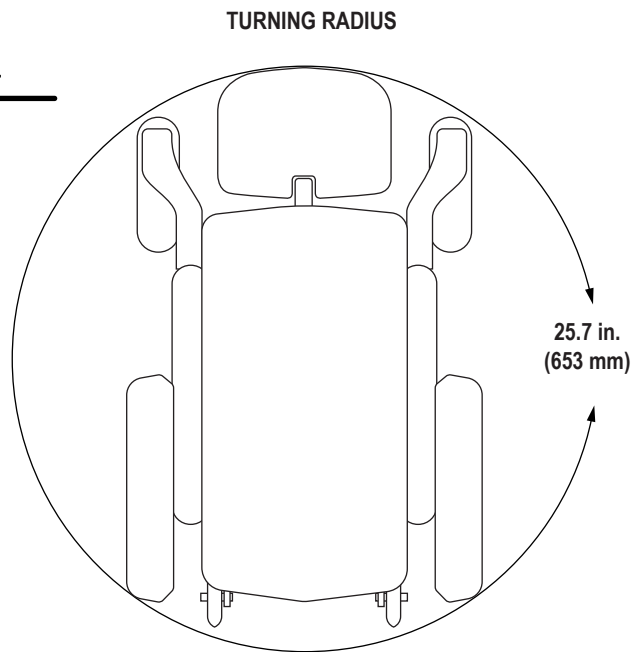
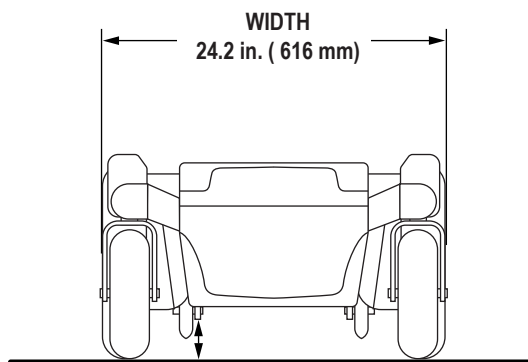
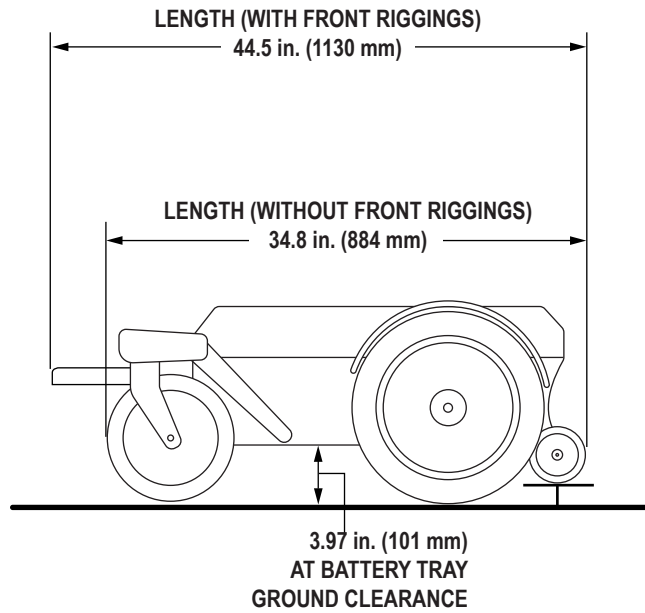

Rev B/August 2023

